

MOTOR 3-PHASE

Worm gear motor IE2 3x230/400 V, 50 Hz

F22180210

180/200



- Adapted for variable speed control
- Aluminium coating for better thermal dissipation
- Built-in thermal contact, drawn to terminal
- Compact built-in dimensions according to IEC-standards
- Extended output shaft
- Two-year product warranty

DIMENSIONS

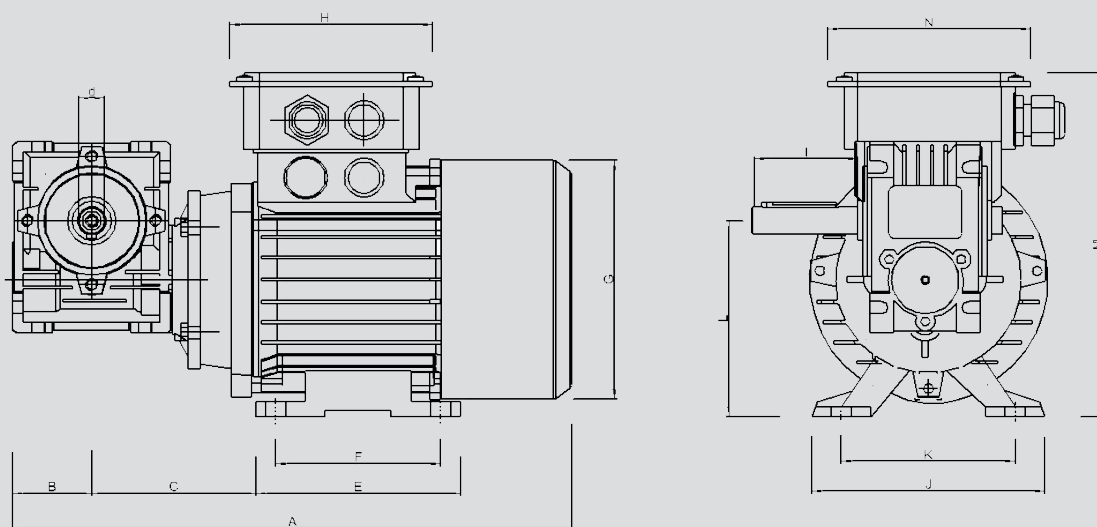

Construction dimensions (mm)

MOTOR	A	B	C	d	E	F	G	H	I	J	K	L	M	N
180/200	286	40	85	14	105	80	123	101	61	120	100	93	165	101

Technical data at 50 Hz

Motor	180/200
Efficiency class	IE2
Poles	4
Rated output	180 W
Rated current 230/400 V	1,2/0,7 A
Connection voltage	3x230/400 V
Rated speed output gear	200 rpm
Ambient temperature	-15 - +40 °C
Maximum operating temperature	<+40 °C
Rated torque output gear	6,0 Nm
Gear ratio	1:7
Protection form	IP55
Weight	5,2 kg

Max rotor diameter at rotor speed 12 rpm

Drivmotor	180/200
Rotordiameter	2500 mm

Other data

When run with our control units, the motor must be D-connected (3 x 230 V).