

## MOTOR 3-PHASE

# Worm gear motor IE3 3x230/400 V, 50 Hz

F22750200

1500/200

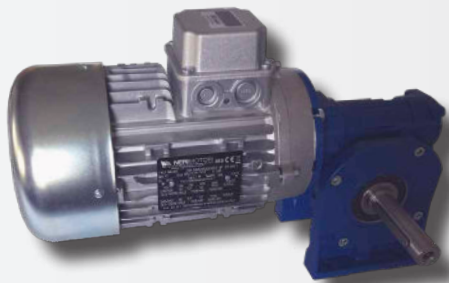

- Adapted for variable speed control
- Aluminium coating for better thermal dissipation
- Built-in thermal contact, drawn to terminal
- Compact built-in dimensions according to IEC-standards
- Extended output shaft
- Two-year product warranty

## DIMENSIONS

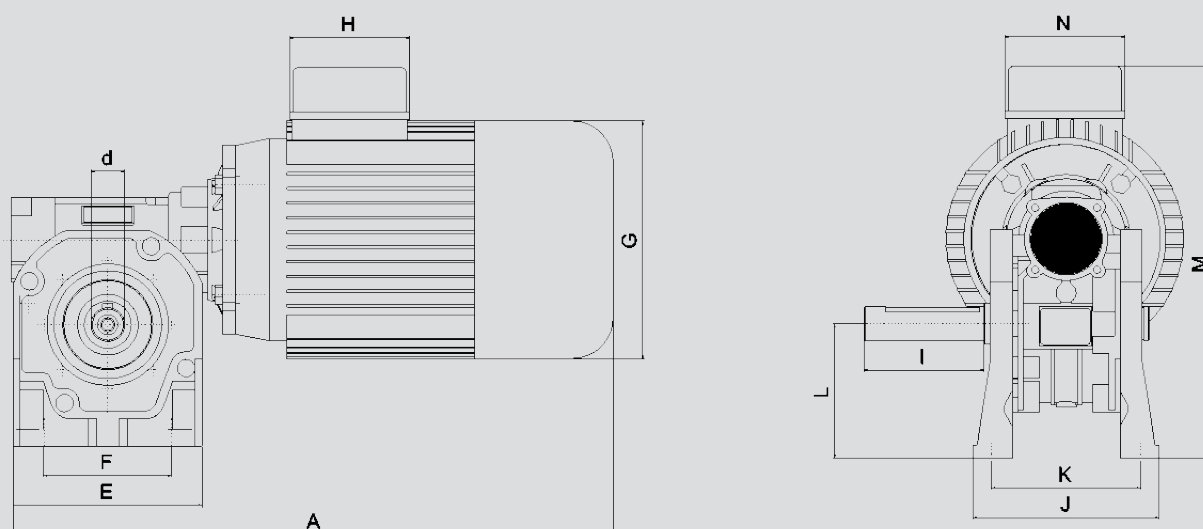

### Construction dimensions (mm)

MOTOR	A	d	E	F	G	H	I	J	K	L	M	N
1500/200	445	25	140	95	176	91	89	138	111	100	291	91

### Technical data at 50 Hz

Motor	1500/200
Efficiency class	IE3
Poles	4
Rated output	1500 W
Rated current 230/400 V	5,7/3,3 A
Connection voltage	3x230/400 V
Rated speed output gear	200 rpm
Ambient temperature	-15 - +40 °C
Maximum operating temperature	<+40 °C
Rated torque output gear	68,2 Nm
Gear ratio	1:7
Protection form	IP55
Weight	24,7 kg

### Max rotor diameter at rotor speed 12 rpm

Motor	1500/200
Rotor diameter	8000 mm

### Other data

When run with our control units, the motor must be D-connected (3 x 230 V).