

## MOTOR 3-PHASE

# Worm gear motor IE1 3x230/400 V, 50 Hz

F22090068

90/68

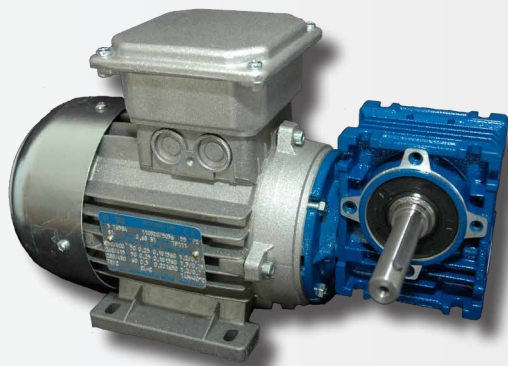

- Adapted for variable speed control
- Aluminium coating for better thermal dissipation
- Built-in thermal contact, drawn to terminal
- Compact built-in dimensions according to IEC-standards
- Extended output shaft
- Two-year product warranty

## DIMENSIONS

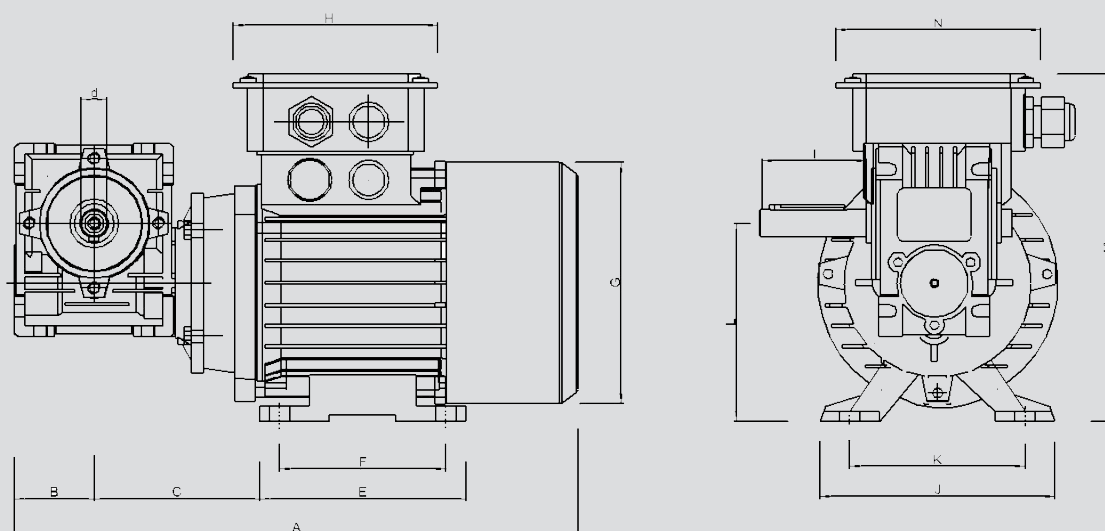

### Construction dimensions (mm)

MOTOR	A	B	C	d	E	F	G	H	I	J	K	L	M	N
90/68	265	40	80	14	90	71	110	101	61	108	90	86	153	101

### Technical data at 50 Hz

Motor	90/68
Efficiency class	IE1
Poles	4
Rated output	90 W
Rated current 230/400 V	0,7/0,4 A
Connection voltage	3x230/400 V
Rated speed output gear	68 rpm
Ambient temperature	-15 - +40 °C
Maximum operating temperature	<+40 °C
Rated torque output gear	7,2 Nm
Gear ratio	1:20
Protection form	IP55
Weight	3,9 kg

### Max rotor diameter at rotor speed 12 rpm

Motor	90/68
Rotor diameter	1500 mm

### Other data

When run with our control units, the motor must be D-connected (3 x 230 V).