

MOTOR 3-PHASE

In line helical gear motor 3x230 V, 50 Hz

F22040075

40/75

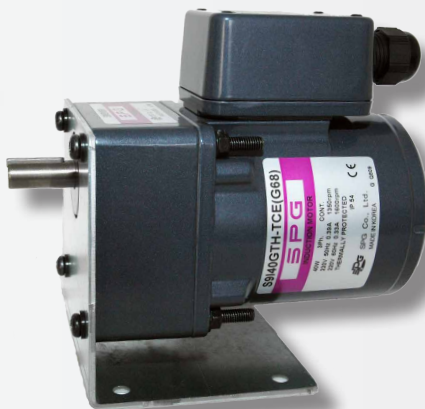

- Adapted for variable speed control
- Built-in thermal contact, drawn to terminal
- Compact built-in dimensions
- Two-year product warranty

DIMENSIONS

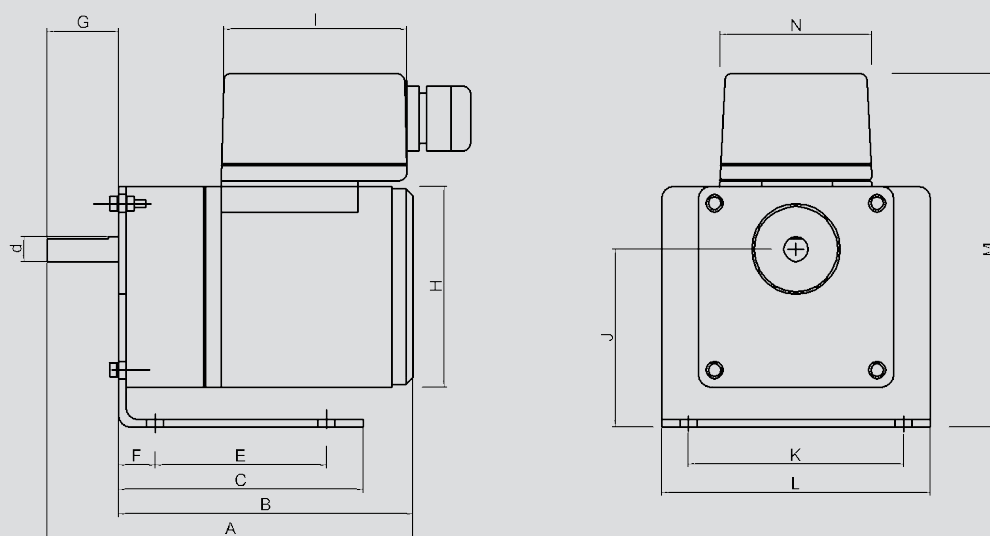

Construction dimensions (mm)

MOTOR	A	B	C	d	E	F	G	H	I	J	K	L	M	N
40/75	180	150	100	12	70	15	30	87	76	85	88	110	160	62

Technical data at 50 Hz

Motor	40/75
Rated output	40 W
Rated current at 230 V	0,39 A
Rated speed	75 rpm
Gear ratio	1:18
Rated torque	4,1 Nm
Protection form	IP54
Connection voltage	3x230 V
Weight including motor bracket	3,9 kg

Max rotor diameter at rotor speed 12 rmp

Motor	40/75
Rotor diameter	1400 mm