

MOTOR 1-PHASE

In line helical gear motor 1x230 V, 50 Hz

F22006080

6/80



- Adapted for on/off run alternatively by MicroStart
- Built-in thermal contact, not drawn to terminal
- Compact built-in dimensions
- Two-year product warranty

DIMENSIONS

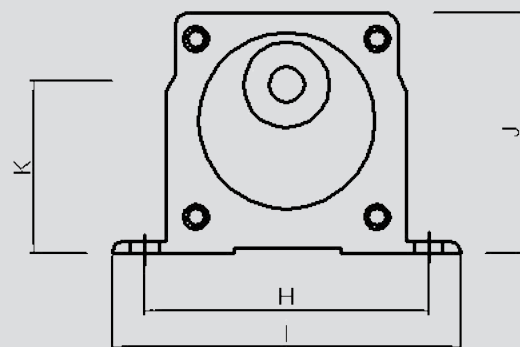
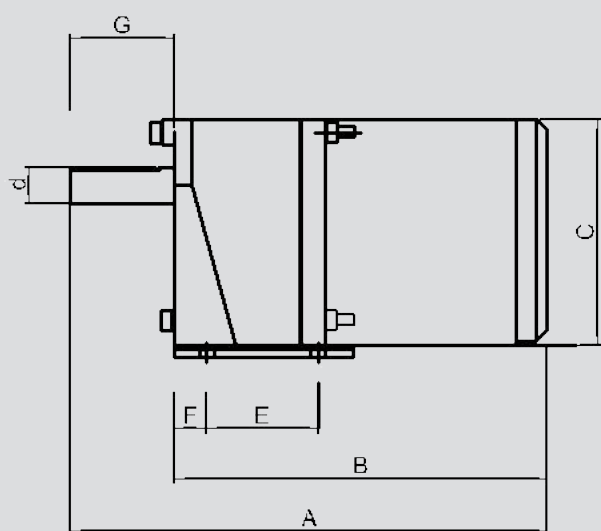

Construction dimensions (mm)

MOTOR	A	B	C	d	E	F	G	H	I	J	K
6/80	135	110	60	8	25	15	28	83	100	67,5	48

Technical data at 50 Hz

Motor	6/80
Rated output	6 W
Rated current at 230 V	0,08 A
Rated speed	80 rpm
Gear ratio	1:15
Rated torque	0,5 Nm
Protection form	IP23
Connection voltage	1x230 V
Weight	1,0 kg
Motor capacitor	0,6 uF

Max rotor diameter at rotor speed 12 rpm

Motor	6/80
Rotor diameter	450 mm