

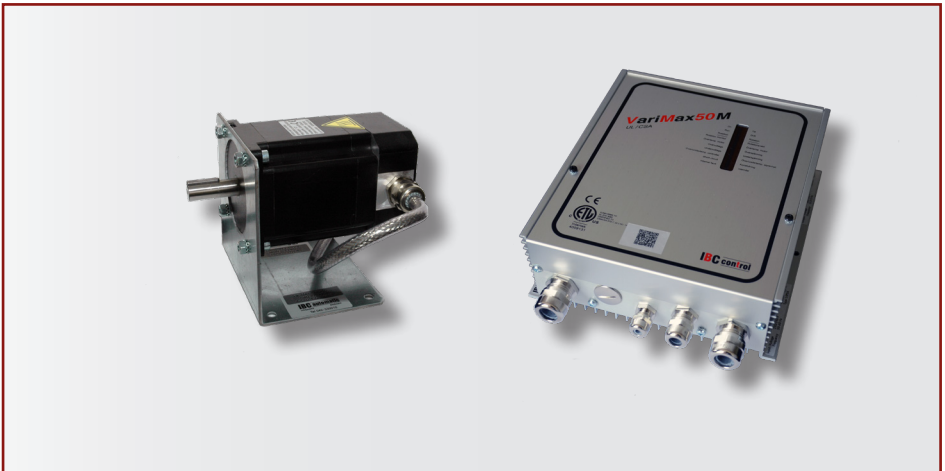

## MANUAL



CONTROL UNIT FOR ROTARY HEAT EXCHANGER WITH MODBUS

# VariMax50M

UL/CSA

Article no. F21050304

**IBC**control



## TABLE OF CONTENTS

Installation instructions	2	Modbus	13
Mounting	2	Technical data, Modbus	15
Safety instructions	3	Connection	15
Manufacturer's declaration		Function settings, Modbus	16
Declaration of conformity	4	Operational indications, Modbus	17
Description of functions	5	Timeout	17
Technical data, control unit	6	DIP switch	18
Technical data, motor	6	Modbus Register Folder	19
Functions	6	Coil	19
- DIP switch	7	Discrete input	20-21
- Operational indications	7	Input register 16-bits	22-23
- Alarms	7	Input register 32-bit	24-25
- Settings via potentiometer	8	Holding register	26
- Reset	8	Personal notes	27-29
Connection diagram	9		
Connections	9		
Input signal/Rotation speed	10		
Checks before powering up the control unit	10		
Commissioning the equipment	10		
EMC installation	11		
EMC gland	11		

## INSTALLATION INSTRUCTIONS

### Warning indication



The control unit must only be used in perfect technical condition. Any damage that may affect safety must be dealt with immediately.

### Maintenance/Repairs

The function of the control unit should be checked regularly. Troubleshooting and repairs must only be performed by trained personnel. Prescribed electrical protection must be implemented.

### Disposal and recycling

When replacing components or when the control unit in its entirety needs replacing, please follow the advice below: The aim shall always be to achieve the maximum possible recycling of raw materials, with the minimum possible environmental impact. Never dispose of electrical components with ordinary waste; always use the designated collection points. Disposal should be effected as environment-friendly as the technology allows in terms of environmental protection and recycling.

## MOUNTING

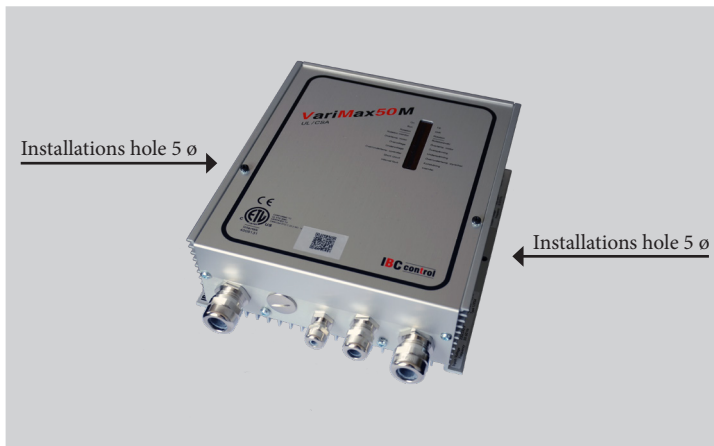

## SAFETY INSTRUCTIONS

The following symbols and references will be used in this description. These instructions are important; they apply to personal and technical safety during operation.



This safety instruction refers to instructions whose specific intent is to avoid the risk of personal injury and to prevent damage to equipment.



Lethal Danger! Electrical components are powered by electrical current!

NB! Switch off main power before removing the cover.

Never touch electrical components or contacts while main current is switched on. Risk of electrocution, resulting in serious injury or death.

Connected terminals contain residual voltage even after the main current has been switched off.

## MANUFACTURER'S DECLARATION DECLARATION OF CONFORMITY

<b>Manufacturer</b>	IBC control AB Brännerigatan 5 A SE-263 37 Höganäs Sweden Tel: +46 42 33 00 10
<b>Product</b>	Control unit for rotary heat exchanger
<b>Type designation</b>	VariMax50M
<b>Applicable EU Directives</b>	EMC Directive 2014/30/EU Low Voltage Directive 2014/35/EU RoHS Directive 2011/65/EU including Delegated Directive EU2015/863
<b>Applicable UK Directives</b>	The Electromagnetic Compatibility Regulations 2016 The Electrical Equipment (Safety) Regulations 2016 The Restriction of the Use of Certain Hazardous Substances in Electrical and Electronic Equipment Regulations 2012
<b>Harmonizing standards for EU/UK Directives</b>	BS EN 61800-3:2004 - Emission kategori C1, Immunitet kategori C2 BS EN 61800-5-1/2 - The control unit is intended for installation in environments with a pollution rating of 2 (Pollution degree 2)
<b>UL/CSA ETL 4009131</b>	Approved under UL508C, and CSA C22.2 No 14. The associated VariMax Motor50 is approved under UL 1004-1, UL 1004-3 and CSA C22.2 No 100

This declaration of conformity is issued under the full responsibility of the manufacturer

Höganäs 2021-09-01

IBC control AB



Christer Persson

MD



---

The FreeRTOS v6.1.0 (<http://www.freertos.org>) software is used in this product and this source code can be supplied by us.

## DESCRIPTION OF FUNCTIONS

- The VariMax50M is a control device with embedded Modbus communication. Technical data for Modbus can be found on page 13-26. The control function can also be used with a normal 0-10 V input signal. Refer to page 6-11.
- The VariMax50M is part of a range of control units adapted for optimum control of rotary heat exchangers, with the necessary additional functions. The range consists of three sizes: VariMax25M, VariMax50M and VariMax100M. All control units run a 3-phase stepping motor. All control units have an input signal of 0-10 V.
- The VariMax50M is designed for rotors up to 2500 mm with a rotor speed of max. 12 rpm. If the rotor requires a faster rotor speed, the rotor diameter should be reduced.
- The VariMax50M has built-in input signal shift, which means that the rotor's efficiency is proportional to the input signal.
- The VariMax50M has a preset threshold value of 0,1 V (hysteresis 0,13–0,07 V). If the input signal falls below this value, the rotor will stop.
- The VariMax50M has a rotation monitor (magnet mounted on the rotor with associated magnet sensor) and a built-in cleaning function. The functions can be disconnected via DIP switches.
- The VariMax50M starts automatically after voltage drop-out, and resets all alarms on restart. 
- The VariMax-motor50 is a stepper motor with substantial moment over the entire speed range.
- When the motor is stationary, a holding torque is activated, which means that the rotor always remains still. The holding torque disappears if the voltage to the control unit is lost.
- The motor is mounted with a 3 m cable as standard.

## TECHNICAL DATA, CONTROL UNIT

Connection voltage	1x230-240 V +/- 15 % 50/60 Hz	Output frequency	0-312 Hz
Power input, max.	240 W	Acceleration and retardation time	30 sec
Input current, max.	1,9 A	Ambient temperature, non condensing	-30 - +45 °C -40 - +45 °C (***)
External fuse, max.	10 A	Protection form	Type 1
Output voltage*)	3x0-280 V	Weight	1,2 kg
Motor current/phase	2 A	Dimensions, HxWxD	203x187x70 mm
Internal fuse **)	2,5 AT		

\*) Exact value cannot be obtained with a digital measuring instrument

\*\*) The fuse protects both motor and electronics

\*\*\*) Note, The control unit must be connected to power all the time

## TECHNICAL DATA, MOTOR

Max. moment	4 Nm	Ambient temperature	-30 - +45 °C -40 - +45 °C (***)
Min. rotation speed	1 rpm	Protection form	IP54
Max. speed (RPM)	375 rpm	Weight incl. motor bracket	4 kg
Motor temperature mantle max	110 °C	Dimensions incl. shaft and motor bracket	130x130x171 mm HxWxL
Shaft diameter	14 mm		
Shaft length	40 mm		

\*\*\*) Note, The control unit must be connected to power all the time

## FUNCTIONS

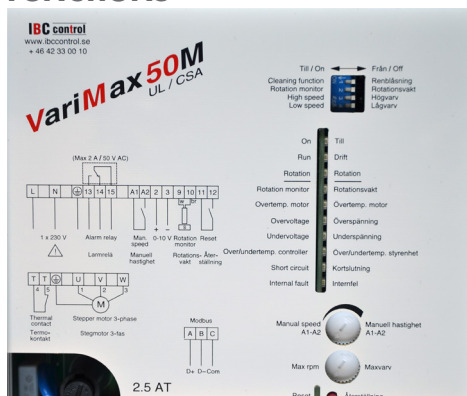

← DIP switch  
ON to left

← Operational indications

← Alarm indications

← Settings

← Reset button



## DIP SWITCH

<b>Cleaning function</b>	Cleaning function connected in ON position. When the rotor has stopped for 10 minutes, the cleaning function is activated and the rotor starts to rotate. As a warning, the rotor first rotates for 6 seconds at a motor speed of 5 rpm, the rotor is then stationary for 3 seconds. After this, the actual cleaning starts, for a random time, between 10 to 20 seconds with the motor at 20 rpm.
<b>Rotation monitor</b>	Rotation monitor connected in ON position.
<b>High speed *)</b>	The rotor rotates at the set max. rpm when the switch is set to ON. After a test run, make sure the DIP switch is set to OFF.
<b>Low speed *)</b>	The rotor rotates at the preset min. speed (1 rpm) when the switch is set to ON. After a test run, make sure the DIP switch is set to OFF.

\*) Manual operation (test mode)

## OPERATIONAL INDICATIONS

<b>On/Alarm</b>	"Voltage on" comes on with a fixed light. Flashes when the control unit has tripped.
<b>Run</b>	Comes on when the motor is to rotate, i.e. when the input signal exceeds the threshold value.
<b>Rotation</b>	Flashes when the magnet passes the magnetic sensor, regardless of the rotation sensor DIP switch setting. Flashes even if the input signal is lower than the threshold value.

## ALARMS

In the event of an alarm the control unit restarts after 30 seconds. The respective red light diode comes on for the same duration (30 seconds).

After restart the light diode goes out, this happens twice. The third time, the alarm relay closes and the alarm "moves on". In order for the alarm relay to close and the alarm to "move on", the above three alarm signals must occur within 90 minutes, otherwise the sequence is reset.

A steady green LED is activated for the first and second alarm and begins to flash on the third alarm. All alarms subsequently remain active.

<b>Rotation monitor</b>	Generates an alarm and trips if a pulse has not been received every 30 minutes at minimum speed (1 rpm) and every 20 seconds at maximum speed (375 rpm). The time between these speeds is linear. The function can be disconnected via DIP switches.
-------------------------	--

Continued on next page

Continued from previous page

Probable fault cause during installation	<ul style="list-style-type: none"><li>- Magnet turned the wrong way</li><li>- Rotation monitor incorrectly connected (wrong polarity), refer to "connections" on page 9</li><li>- Gap too wide between the magnetic sensor and magnet; max 15 mm</li></ul>
Probable fault cause in operation	<ul style="list-style-type: none"><li>- Broken belt</li><li>- Belt slipping</li><li>- Stuck rotor</li><li>- Magnetic sensor or magnet not intact</li></ul>
<b>Overtemperature motor</b>	Alarms and trips if motor winding temperature is too high. The temperature switch in the motor reverts to normal mode when the temperature drops.
<b>Overvoltage</b>	Alarms and trips if the input voltage exceeds 265 V.
<b>Undervoltage</b>	Alarms and trips if the input voltage falls below 190 V.
<b>Over/under-temperature</b>	Alarms and trips if the temperature in the control unit goes above/below safe temperature level (+85 - -30 °C).
<b>Short circuit</b>	Alarms and trips in the event of short circuit phase-phase or phase-earth.
Probable cause	<ul style="list-style-type: none"><li>- Short circuit between phases in cable or motor</li><li>- Short circuit between phase-earth in cable or motor</li><li>- Interruption to one phase in cable or motor</li><li>- No motor or wrong motor connected</li></ul> Measure motor resistance; it should be identical on all coils.
<b>Internal fault</b>	Alarms and trips if an internal fault in the control system has occurred.

## SETTINGS VIA POTENTIOMETER

<b>Manual speed</b>	By closing A1-A2 the speed is controlled via the potentiometer marked "Manual speed". Can be regulated between 1 and 375 rpm. The rotor rotates at the set speed, whatever the value of the input signal. Factory setting: 1 rpm on motor shaft.
<b>Max rpm</b>	Potentiometer for adjusting max rpm. Regulates between 50 and 375 rpm. Factory setting: 50 rpm on motor shaft.

## RESET

<b>Reset</b>	Reset button for resetting the control unit. The control unit is also reset in the event of voltage drop-out and closure between terminals 11 and 12.
--------------	---

## CONNECTION DIAGRAM

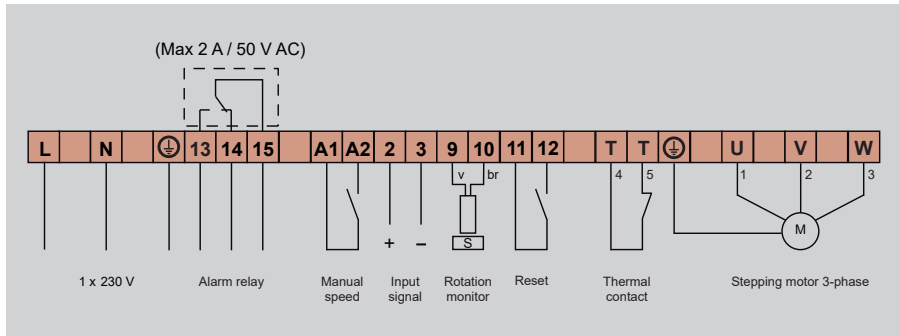

## CONNECTIONS



The voltage must be switched off before undertaking any work on the equipment.  
Recommended torque 0,5 Nm, max. torque 0,8 Nm.

<b>Connection voltage (L-N-PE)</b>	1x230-240 V +/- 15 %, 50/60 Hz. NOTE! Protective earth must always be connected.
<b>Alarm relay (13-14-15)</b>	Closes between 14-15 in the event of an alarm or voltage drop-out. Max 2 A resistive load / 50 V AC.
<b>Manual speed (A1-A2)</b>	Produces set rotation speed on connection.
<b>Input signal (2-3)</b>	0-10 V. Plus connected to terminal 2, minus to terminal 3.
<b>Rotation monitor (9-10)</b>	White cable connected to terminal 9, brown to terminal 10. The magnet is installed with south side (S) towards the sensor. Max. gap 15 mm.
<b>12 V output (3-11)</b>	Output for 12 V DC. Terminal connection 3 is minus (-), terminal connection 11 is plus (+). Max 50 mA.
<b>Reset (11-12)</b>	Remote reset in the event of alarm. The control unit is reset automatically in the event of voltage drop-out.
<b>Thermal contact (T-T)</b>	 This must be connected to protect the motor against overheating.
<b>Motor (U-V-W)</b>	VariMax-motor50 must be used. Direction of rotation is changed by switching two of the phases.

## INPUT SIGNAL/ROTATION SPEED

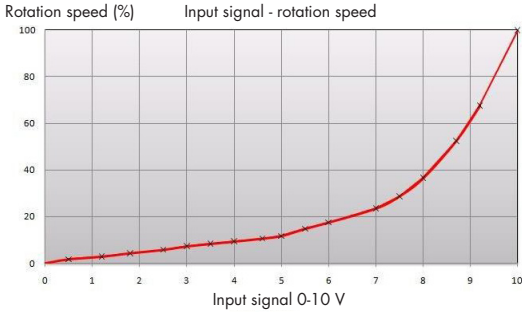

The input signal is directly proportional to the efficacy of the rotor, which implies that input signal and rotation speed are as per the adjacent diagram.

## CHECKS BEFORE POWERING UP THE CONTROL UNIT



- |                   |  |
|-------------------|--|
| <b>Check that</b> | the control unit is connected as per instructions on page 9.<br>Connection voltage 1x230-240 V +/-15%, 50/60 Hz. |
| <b>Check that</b> | the input signal is 0-10 V.  |
| <b>Check that</b> | the rotation monitor and cleaning function are connected.  |

## COMMISSIONING THE EQUIPMENT



Should be accomplished in sequence

- |                                       |   |
|---------------------------------------|---|
| <b>Check that</b>                     | the motor rotates in the right direction in relation to the rotor's direction of rotation. In the event of a fault, switch two phases to the motor.   |
| <b>Adjustment of max. speed</b>       | Set the High Speed DIP switch to the ON position.<br>Adjust "Max rpm" so that the rotor rotates at 10-12 rpm (or as per rotor manufacturer's directions).<br>After a test run, set the DIP switch to OFF.             |
| <b>Checking min. speed</b>            | Set the Low Speed DIP switch to ON.<br>Check that the rotor starts.<br>The minimum speed is preset.<br>After a test run, set the DIP switch to OFF.   |
| <b>Checking the cleaning function</b> | Switch off the voltage.<br>Make sure the "Cleaning function" DIP switch is set to ON and the input signal is disconnected.<br>After switching on the voltage the rotor rotates for 20 seconds at 12 rpm on the motor. |
| <b>Checking the rotation monitor</b>  | The yellow Rotation LED will flash when the magnet passes the magnetic sensor, regardless of DIP switch position.   |
| <b>Finish by</b>                      | having the control unit drive the rotor at maximum and minimum rotation speeds and checking that the operating rotor speed is correct.  |

## EMC INSTALLATION

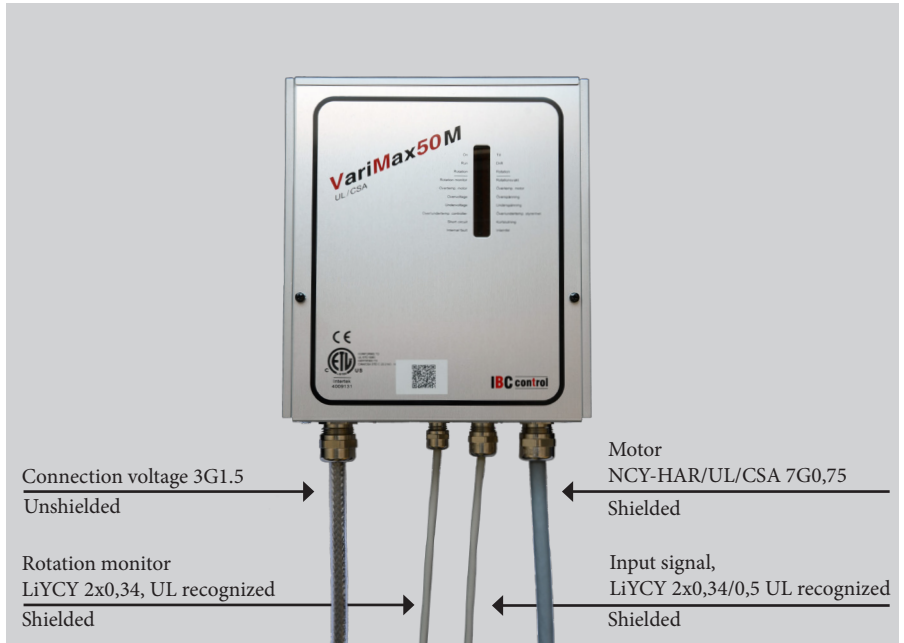

EMC glands must be used for shielded cables.

The above cables or equivalent must be used to comply with the EMC Directive.

## EMC GLAND

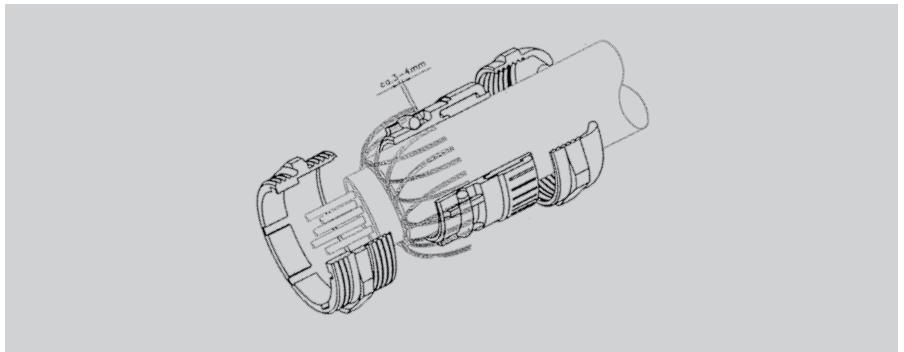

NOTE!

When connecting the shielding to the EMC gland, it is important to connect as shown above.



# Modbus





## TECHNICAL DATA, MODBUS

Communication protocol	MODBUS RTU
Interface	RS485, half-duplex
Data rate	9 600, 19 200, 38 400, 56 000 bits per second
Bit format	8 databits, 1 stop bit, even parity 8 databits, 1 stop bit, no parity 8 databits, 2 stop bits, no parity 8 databits, 1 stop bit, odd parity
Address	8 unique addresses, refer to the table "Addressing" page 18
Termination	Optional embedded terminal resistance 120 $\Omega$
Inputs	3-pole terminal block marked A (D+), B (D-), C=common

## CONNECTION

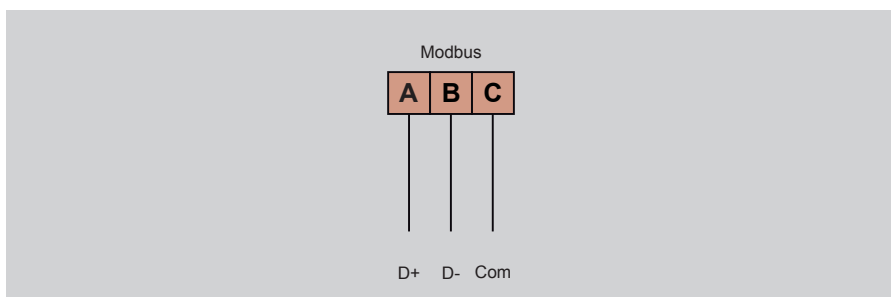

A	D+, positive data channel
B	D-, negative data channel
C	Common, signal earth

## FUNCTION SETTINGS, MODBUS

Activation of Modbus communication and configuration of address, data transfer rate, parity and termination are achieved through a 9-pole DIP switch. On delivery of the unit all DIP switches are set to their OFF position. For setting and configuration of the DIP switches refer to the table on page 18.

Modbus communication is activated through DIP switches. A constant red LED starts to light straight away if no message with the speed setpoint has been received. This goes out once the message with the speed setpoint has been received. A green LED starts flashing if there is data traffic present in the bus.

Settings made via Modbus are not saved in VariMax50M. When VariMax50M is restarted the setting from the DUC has to be re-transmitted.

<b>Cleaning function and rotation monitor</b>	The function will start in the manually selected position on the control unit's DIP switch (refer to picture on page 18), but it is possible to change this via Modbus. When the Modbus communication is activated the manual settings give the settings for cleaning function and rotation monitor a start value, but Modbus has priority.
<b>High speed/Low speed</b>	High speed/Low speed are not controlled via Modbus. Refer also to "High speed/Low speed" on page 7.
<b>Manual speed A1-A2</b>	A1-A2 has priority over Modbus. Manual speed can be read and activated via Modbus if A1-A2 are not connected. Refer also to "Manual Speed" on page 8.
<b>Max rpm</b>	Max rpm is set via the potentiometer. The DUC is configured so that 100 % of the setpoint equates to the set rpm speed. Refer also to "Max rpm" on page 8.
<b>Resetting</b>	Resetting can be made via Modbus, via the Reset button or via Remote Reset. Refer also to "Resetting" on page 8 and "Remote Reset" on page 9.
<b>Input signal</b>	This is controlled via Modbus.
<b>Rotor speed</b>	The rotor speed can be read via Modbus.

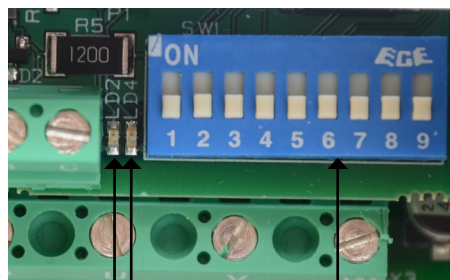
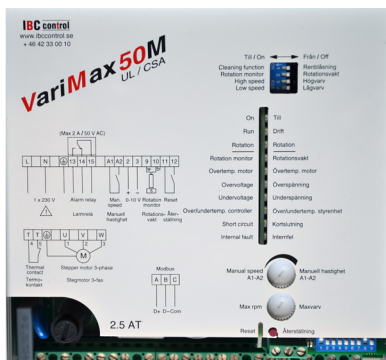

Green LED Red LED

DIP switch

## OPERATIONAL INDICATIONS, MODBUS

Green LED	Red LED	Operating mode	Troubleshooting
Unlit	Unlit	Modbus turned off	
Unlit	Lit with fixed light	No communication	<ul style="list-style-type: none"> <li>- Communication cable broken or not connected.</li> <li>- No communication received from host system.</li> </ul>
Unlit	Flashing	Non-interpretable communication	<ul style="list-style-type: none"> <li>- Incorrect speed setting</li> <li>- Incorrect number of stop bits or parity setting</li> <li>- Incorrectly polarised or poorly connected cable</li> <li>- Incorrect termination</li> </ul>
Lit with fixed light	Unlit	Communication established, no traffic on the bus	
Lit with fixed light	Flashing	Communication established, temporary communication error	<ul style="list-style-type: none"> <li>- Poorly connected cable</li> <li>- Incorrect termination</li> </ul>
Flashing	Unlit	Communication established, traffic on the bus	
Flashing	Lit with fixed light	Connected to bus traffic but no setpoint sent to VariMax	<ul style="list-style-type: none"> <li>- Incorrect address set</li> <li>- No setpoint received from host system</li> </ul>

\*VariMax has received a setpoint for the past 90 seconds.

## TIMEOUT

If messages with setpoints stop coming, VariMax50M will continue using the latest received setpoint. After 90 seconds the red LED will activate.

## DIP SWITCH

		1	2	3	4	5	6	7	8	9
<b>Modbus communication On</b>		1								
<b>Addressing</b>										
<b>Hexadecimal</b>	<b>Decimal</b>									
10	16		0	0	0					
11	17		1	0	0					
1E	30		0	1	1					
28	40		0	1	0					
29	41		1	1	0					
90	144		0	0	1					
91	145		1	0	1					
A9	169		1	1	1					
<b>Rate</b>										
9 600						0	0			
19 200						1	0			
38 400						0	1			
56 000						1	1			
<b>Package</b>										
1 stop bit, even parity								0	0	
1 stop bit, no parity								0	1	
2 stop bits, no parity								1	0	
1 stop bit, odd parity								1	1	
<b>Termination To</b>										1

## MODBUS REGISTER FOLDER

VariMax50M supports the following Modbus functions:

- ◆ Coil (digital Read/Write)
- ◆ Discrete input (digital Read)
- ◆ Input register (analogue Read)
- ◆ Holding register (analogue Read/Write)

### COIL

1-bit register (Read/Write).

Modbus function 01 "Read Coil Status" is used for reading.

Modbus function 05 "Force Single Coil" is used for writing.

0 = not active

1 = active

Address	Name	Designation	Data form	Read/Write	Factor	Unit
1	Reset alarm	Write 1 for resetting the alarm.	Single bit	Read/Write		
2	Cleaning function	Reads 1 if the cleaning function is active. A Write on this address implies that Modbus assumes control of this function. Write 1 to activate cleaning function or 0 to deactivate.	Single bit	Read/Write		
3	Rotation monitor	Reads 1 if the rotation monitor is active. A Write on this address implies that Modbus assumes control of this function. Write 1 to activate the rotation monitor or 0 to deactivate.	Single bit	Read/Write		
4	Manual speed	Reads 1 if the manual speed is active. Write 1 to activate manual speed instead of the control signal from Modbus. If the function is activated via the digital input it cannot be deactivated via Modbus.	Single bit	Read/Write		

## DISCRETE INPUT

1-bit status register (Read).

Modbus function 02 "Read Input Status" is used for reading.

Reads 1 if a fault has occurred.

0 = normal

1 = alarm

Address	Name	Designation	Data form	Read/Write	Factor	Unit
1	Error	Error regardless of which fault has occurred.	Single bit	Read		
2	Tripped control	Control has tripped and cannot reset itself	Single bit	Read		
3	Motor temperature	Motor overheating	Single bit	Read		
4	Low temperature	Low temperature in the control unit	Single bit	Read		
5	Overheating AC	Overheating in the control unit	Single bit	Read		
6	Undervoltage AC	Low supply voltage	Single bit	Read		
7	Voltage surge AC	High supply voltage	Single bit	Read		
8	Surge	Several surge events	Single bit	Read		
9	Rotation monitor	Alarm, rotation monitor	Single bit	Read		
10	Rotating rotor	Rotor rotates during startup	Single bit	Read		
11	Overcurrent	Overcurrent in the motor	Single bit	Read		
12	Overload, fast	Overload	Single bit	Read		
13	Overload	Overload	Single bit	Read		
14	Underload	Push load	Single bit	Read		
15	Motor control	Error in motor control	Single bit	Read		

Continued on next page

Continued from previous page

Address	Name	Designation	Data form	Read/Write	Factor	Unit
16	Short circuit	Short circuit	Single bit	Read		
17	Short circuit	Imbalance between phases	Single bit	Read		
18	Short circuit	Phase 1 missing	Single bit	Read		
19	Short circuit	Phase 2 missing	Single bit	Read		
20	Short circuit	Phase 3 missing	Single bit	Read		
21	Short circuit	Motor impedance low. Incorrect motor impedance e.g incorrect size of motor, failed motor or bad connections.	Single bit	Read		
22	Short circuit	Motor impedance high. Incorrect motor impedance e.g incorrect size of motor, failed motor or bad connections.	Single bit	Read		
23	Internal fault	Internal fault in the control unit.	Single bit	Read		

## INPUT REGISTER

16-bit register (Read).

Modbus function 04 "Read Input Registries" is used for reading.

Address	Name	Designation	Data form	Read/Write	Factor	Unit
1	Program version IOC		UINT 16	Read	100	
2	Program version MPC		UINT 16	Read	100	
3	VariMax model	Reads 50 for VariMax50 etc.	UINT 16	Read		
4	Temperature	Temperature in the control unit	INT 16	Read		°C
5	AC voltage	Supply voltage for VariMax	UINT 16	Read		V
6	Operating mode	Source for speed setpoint(s) in current use: 1 = Low speed DIP switch ON 2 = High speed DIP switch ON 3 = Manual speed 17 = Control signal 32 = No operation. Cleaning function OFF 36 = No operation. Cleaning function ON 44 = Cleaning function in progress.	UINT 16	Read		
7	Current setpoint for speed (rpm)		UINT 16	Read	100	rpm
8	Current motor axle speed		UINT 16	Read	100	rpm
9	Maximum motor axle speed	Static value that advises the max speed the control unit can operate at.	UINT 16	Read	100	rpm

Continued on next page



Continued from previous page

Address	Name	Designation	Data form	Read/Write	Factor	Unit
10	Current rotor speed	<p>Only calculated if the speed setpoint remains constant between two pulses on the rotation monitor. Displays 0 if no value is available.</p> <p>To ensure the correctness of the measured value the speed setpoint should be changed. This will cause the registry to read as 0 until the current value is displayed.</p>	UINT 16	Read	100	rpm
11	Error code	Reads 0 if no error, 3-23 error code according to Discrete inputs, other codes internal faults.	UINT 16	Read		
12	Tripped control	Reads 1 if VariMax has tripped.	UINT 16	Read		

## INPUT REGISTER

32-bit register (Read).

Modbus function 04 "Read Input Registries" is used for reading.

Address	Name	Designation	Data form	Read/Write	Factor	Unit
33*	Motor speed RPM	Number of rotations	UINT 32	Read		
35*	Motor starts	Number of motor starts	UINT 32	Read		
37*	Restarts	Number of faults causing restarts	UINT 32	Read		
39*	Surge	Number of surges detected	UINT 32	Read		
41*	Modbus connections	Number of dropped connections in Modbus	UINT 32	Read		
43*	Modbus packets ok	Number of OK packets in Modbus	UINT 32	Read		
45*	Modbus packets error	Number of faulty packets in Modbus	UINT 32	Read		
47*	Total operating time	Total operating time for the control unit	UINT 32	Read		s
49*	Fault waiting time	Time with an active fault/error	UINT 32	Read		s
51*	Time with abnormal supply voltage	Time with abnormally high or low supply voltage	UINT 32	Read		s
53*	Stop time, high temp.	Time with stopped motor, in excess of 75 °C	UINT 32	Read		s
55*	Stop time, warm temp.	Time with stopped motor, 40-75 °C	UINT 32	Read		s

Continued on next page

Continued from previous page

Address	Name	Designation	Data form	Read/Write	Factor	Unit
57*	Stop time, normal temp.	Time with stopped motor, 0-40 °C	UINT 32	Read		s
59*	Stop time, cold temp.	Time with stopped motor, below 0 °C	UINT 32	Read		s
61*	Running time, high temp.	Time with motor running, in excess of 75 °C	UINT 32	Read		s
63*	Running time, warm temp.	Time with motor running, 40-75 °C	UINT 32	Read		s
65*	Running time, normal temp.	Time with motor running, 0-40 °C	UINT 32	Read		s
67*	Running time, cold temp.	Time with motor running, below 0 °C	UINT 32	Read		s

\* = 32-bit access

## HOLDING REGISTER

16-bit register (Read/Write).

Modbus function 03 "Read Holding Registries" is used for Reading.

Modbus function 06 "Write" Singles Registries" is used for Writing.

Address	Name	Designation	Data form	Read/Write	Factor	Unit
1	Setpoint, relative speed	1000 = 100 % of set max rpm speed. Can be set in excess of 100 %, up to 65535.	UINT 16	Read/Write	10	%
2	Setpoint, efficacy. See "Input signal/rotation speed" page 10	1000 = 100 % of max speed setting.	UINT 16	Read/Write	10	%
3	Setpoint, reference absolute speed	100 = 1 rpm. Absolute speed is not affected by the setting of max. speed setting potentiometer.	UINT 16	Read/Write	100	rpm



## PERSONAL NOTES





## PERSONAL NOTES





## PERSONAL NOTES



F21050904GB  
VERSION 1.1.3  
20220201

**IBC**control

IBC control AB  
Brännerigatan 5 A  
SE-263 37 Höganäs  
Sweden  
Tel. +46 42 33 00 10  
[www.ibcccontrol.se](http://www.ibcccontrol.se)  
[info@ibcccontrol.se](mailto:info@ibcccontrol.se)